

SYNTHESOURCE

Vol 1 No 1

Winter 1981

Curtis IC Line Grows

NEW PRODUCTS

If some of you are wondering why we have been so busy lately, its' because we've been hibernating in the R & D lab cooking up some new products, as well as making improvements to several of our existing chips. Here is a quick run-down on the outcome of all our efforts:

The CEM 3350 Dual State, Variable Voltage Controlled Filter

That's right. This device contains not one but two state variable filters in a single 16-pin DIP. And each has independent control inputs for sweeping frequency over greater than a 12 octave range and Q from less than $\frac{1}{2}$ to greater than 100. Needless to say, the frequency control scales are exponential; but in addition, so are Q control inputs for better resolution at higher Q settings. Other available functions include a fixed gain signal input for constant gain in the passband as the Q is varied, and a variable gain input for constant gain at the resonant frequency. And of course, as in any state variable, low pass, band-pass, and highpass outputs are directly available.

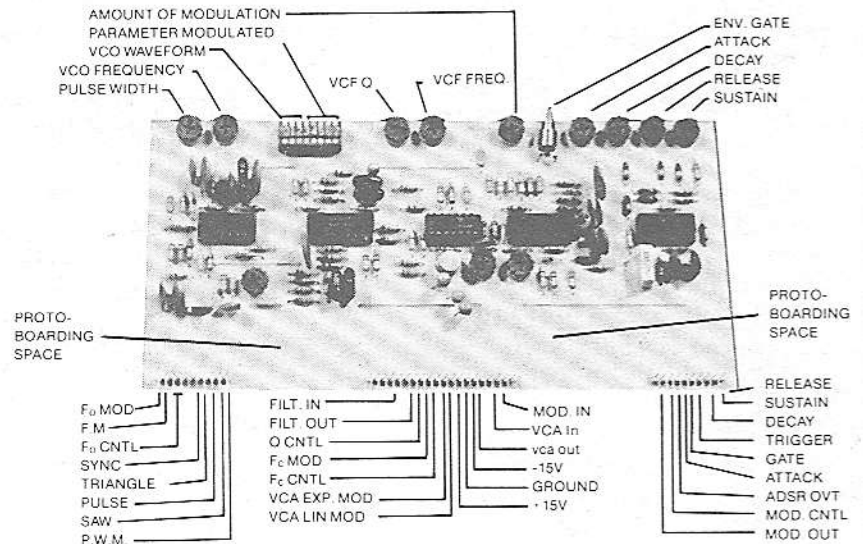

CEV 3301 EVALUATION BOARD

The idea behind this filter was to provide other types of filter responses than the standard 4 pole lowpass that we've come to know and love and start getting tired of. True, the low pass may most closely simulate conventional instruments, but there is a vast variety of sounds out there to be obtained with other filter responses. By combining the two independent filters of the CEM 3350 in different ways, numerous and unusual responses can be created with a high degree of voltage control over the defining parameters. An obvious example is to follow a high pass response with a low pass response as shown in the

CURTIS ELECTROMUSIC

has a new facility and a new address:

110 Highland Avenue
Los Gatos, CA 95030

Our new phone number:
(408) 395-3350

INTERVIEW: Oberheim GIVING THE MUSICIAN MORE FOR HIS FOR HIS MONEY

Once a manufacturer of phase shifters and a distributor of ARP synthesizers, Tom Oberheim's well known product line was born in the early 1970s with a monophonic digital sequencer.

continued on page 5

figure. The result is a bandpass, but with control over the width of the passband as well as its center. In addition, the Q s can be cranked up to add resonant peaks at either, or both, corners.

Another application is to combine all the bandpass outputs of several chips with their inputs tied together. This would produce a bumpy response, where the position and height of the bumps is voltage controllable. Such a bumpy response has been shown to enrich a tone considerably, especially when the various parameters are slowly modulated at different rates.

For those who wish to stay with tradition, the CEM 3350 is still able to produce the standard four pole low pass response as well as, if not better than, any device on the market. The connection is shown in the accompanying figure; in addition to being able to generate much more resonance before oscillation than other

circuits, this configuration requires virtually no more components than even dedicated low pass filter chips.

And, of course, the CEM 3350 performs with the superb specs that the rest of the line has become known for: 50mV typical (-46dB) of control feed-through, output noise below that of the op amp buffers used, and excellent tracking between devices.

Samples of the CEM 3350 are available now, with production available 12 weeks ARO.

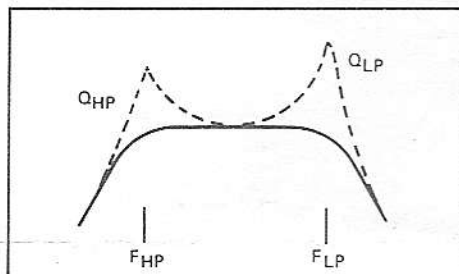

RESPONSE OF BANDPASS FILTER

The CEM 3360 Dual Voltage Controlled Amplifier

Not another dual VCA, you exclaim! The industry has VCAs coming out of their ears. Ah, but this one is different.

First of all, it is extremely easy to use. Each VCA requires but a single input resistor and a single output resistor. That's it. Secondly, the control inputs start at zero volts. Say goodbye to those level shift PNPs you needed for the 3080s and 3280s. Thirdly, you now have a choice of either linear control, or with a few extra resistors, exponential control as well. Add these to summing node signal inputs, wide voltage compliance current outputs, and wide supply range, and you have yourself a pretty nice VCA.

But that's only half of it. The real claim to fame for the CEM 3360 is that you can now also throw away those feed-through trimmers. The CEM 3360 features exceptionally low feedthrough,

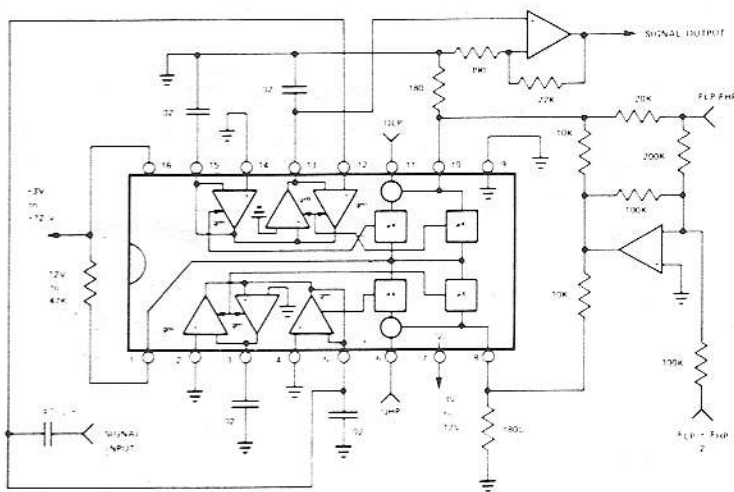

VARIABLE BANDPASS FILTER

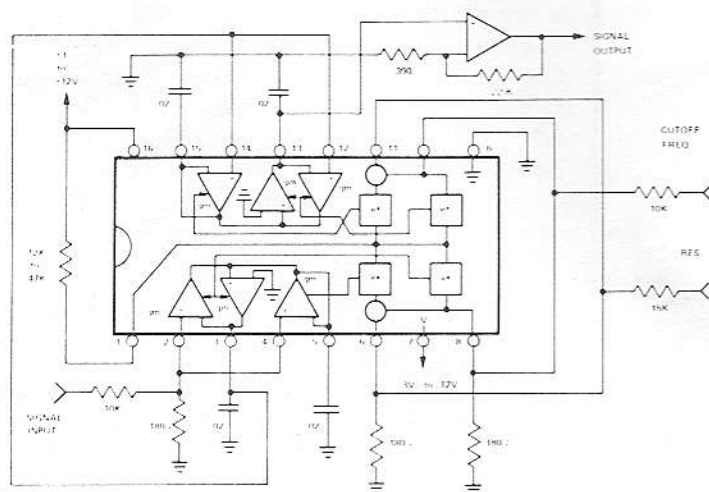

STANDARD 4 - POLE LOW PASS

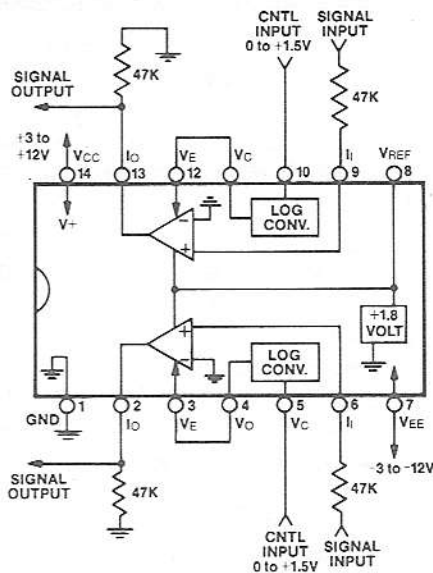

CEM 3360 DUAL VCA

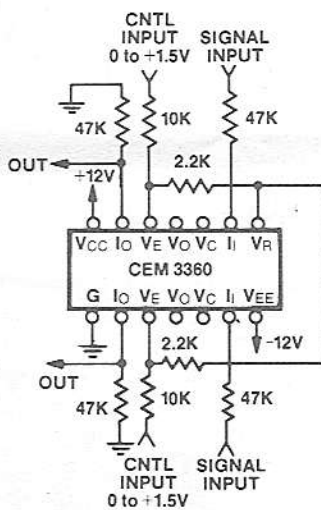

CEM 3360 CONNECTION FOR EXPONENTIAL CONTROL

without trimming. Typical feedthrough is less than 2mV out of a 10V.P.P. output signal, or some 74dB below the average output; and we are guaranteeing 10mV worst case. Again, this low feedthrough is without trimming.

The second most impressive spec is the low noise--better than 100dB

below average output. So now you don't have to worry about feedthrough or noise buildup. Other impressive specs include a bandwidth greater than 1MHz and distortion less than 1%.

True, the CEM 3360 may cost a dollar or so more than what you are presently using*--CA 3080, CA 3280, or LM 13600--but after you subtract the cost of two trimmers, technician time for adjusting them, service time for recalibration after use, and all the headaches that go along with trimmers, you have more than saved the additional cost.

By the way, the CEM 3360 does not supercede or obsolete the CEM 3330. The CEM 3330 is a precision dual VCA, offering linear and exponential control scale accuracies, low distortion, low noise, and low feedthrough that few other (if any) VCAs can match. The CEM 3360, on the other hand, is intended for those less critical applications, now filled by the above mentioned OTAs, where parts count is the main consideration.

Samples of the CEM 3360 are now available, and production can be delivered in 12 weeks, ARO.

* in volume

THE CEV 3301 Evaluation Board

It took us a while, but at long last we have come out with a PC board for evaluating the first four ICs of our line. The CEV 3301 contains one each of the CEM 3310, CEM 3320, CEM 3330, and CEM 3340

along with all the additional circuitry required in a typical application (including a quad op amp). Although the board is primarily intended as a tool for evaluation, we tried to make it as versatile as possible.

We designed the board so each device could be evaluated independently of the others, or as part of a complete system. To this end we brought out numerous signal and control inputs and outputs for each device to one edge of the board and onto a 40-pin, 0.1 inch, right angle male header. This allows the user to easily connect the appropriate test equipment to the card to evaluate any one or all of the ICs. At the other edge of the card, we added an eight SPST DIP switch to allow some limited patching between devices, nine miniature trim pots which can sweep all parameters through their entire ranges, and a sub-miniature push button to trigger the envelope generator. Thus, if so inclined, the user can thoroughly evaluate the four chips as part of simple voice with only a ± 15 volt supply and a sound system. Finally, we filled in the remaining board area with an ample amount of standard proto-boarding space to allow people to construct their own circuit creations.

By now we have more than just an evaluation board: With all the inputs and outputs on the 40-pin right angle header, several CEV 3301s can be soldered into a mother board and interconnected into a larger system, or even a

working, high performance, synthesizer. All the miniature control pots on the top of the board can be used like front panel controls, or actual front panel controls can be easily wired in place of these miniature pots. In addition, the protoboarding space can easily accommodate eight sample and holds with their associate logic to put the whole system under computer control.

To facilitate the use of the CEV 3301 in applications other than evaluation, a number of options are available. With option A, the board comes with a right angle, 0.1 inch female header instead of the male header. Option B comes with no connector, and option C is minus the DIP switch, control pots, and push button. Combinations are also available; for instance, option BC comes with no connector, DIP switch, control pots, or pushbutton.

Complete with full documentation, the CEV 3301 or any of its options is available fully assembled and tested 4-6 weeks ARO. Please contact us for pricing.

Non-OEM users may purchase the CEV3301 completely assembled or as a kit from our non-OEM distributor, PAIA Electronics, 1020 W. Wilshire Blvd., Oklahoma City, OK 73116.

IMPROVEMENTS TO THE CEM
3340 VCO AND CEM 3310
ENVELOPE GENERATOR

Some of you may recall

having received earlier this year an engineering memorandum on the 3340 Voltage Controlled Oscillator. It said in effect that we had discovered in the first production batch a number of chips which exhibited a long term frequency drift when operated at supply voltage near the maximum ratings. In addition to instituting a long term drift test on a sample basis to weed out drifting lots, we recommended that for best stability the CEM 3340 be operated at lower supply voltage (-5, +15 for instance). Well, we were never happy with this plug-up-the-hole-and-hope-it-doesn't-spring-a-leak-again approach, so we began an intensive investigation.

After months of work, we had learned some interesting characteristics about the bipolar process used by our products that was a surprise to even our wafer suppliers. What we found was that a particular arrangement of some chip components had created a parasitic PMOS transistor. Not only did this PMOS transistor appear in our most critical product, but it was injecting small currents which varied with time into the most sensitive part of the circuit. Murphy just would not have it any other way.

Fortunately the fix was relatively simple: A slight rearrangement of the chip components got ride of the PMOS transistor entirely and any potential long term drift. We don't know about you,

TO OUR READERS:

Welcome to the first issue of Synthesource. Through this newsletter we hope to keep you updated on the latest advances in music synthesizer technology, useful circuit application ideas for our line of integrated circuits, company related news, and general interest events happening in the music industry. Probably even more important is that we hope to get a dialog going between you and us, so all feedback, contributions, and articles are welcome.

Synthesource will be published 4 times annually. We are asking that subscriptions be taken at a mere \$12.50 per year to just cover our costs. A subscription form can be found on the last page. Thank you.

Now read on and enjoy.

Doug Curtis

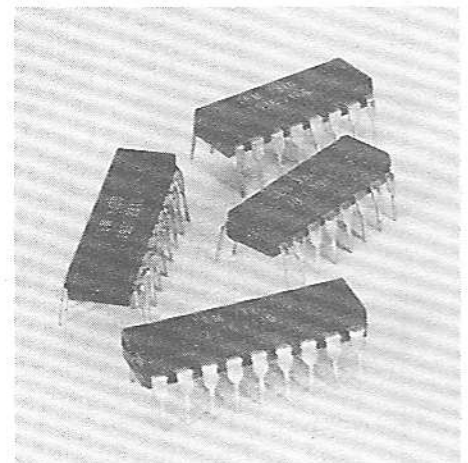

THE FIRST CHIPS
OF THE CURTIS LINE:
CEM 3310 V.C. ENVELOPE
GENERATOR
CEM 3320 VCF
CEM 3330 DUAL VCA, AND
CEM 3340 VCO

but we have been sleeping much better at night now.

The other product improvement was made to the CEM 3310 Voltage Controlled Envelope Generator. Developed and introduced in fall of 1978, this was the first real product of our line. At the time, we had envisioned that the product would only need to operate off the industry standard ± 15 volt supplies. Consequently the minimum positive supply for the 3310 was 12.5 volts.

However, during the development of the subsequent products, we realized that some manufacturers like to operate their circuits from ± 12 volt or even lower supplies for lower power dissipation and higher reliability. We therefore made it a design goal to ensure that all future products be capable of operating down to at least $+10$ volts, with the intention of some day modifying the 3310 to that standard as well.

At last, that day has arrived. All CEM 3310s shipped after November 15, 1980 are capable of operating down to at least 10.5 volts. Other than a 10% increase in supply current, the new version works exactly the same as the older version, with the same high degree of tracking, ultra low control feedthrough, and excellent envelope shape.

Incidentally, our newest products, the 3350 and 3360 are capable of operating down to ± 3 volts. So, get ready for those battery powered synthesizers.

Oberheim (continued)

In those days, all synthesizers were monophonic. So to allow the musician to play the synthesizer and the sequencer at the same time, Oberheim next developed the Synthesizer Expander Module which was a small synthesizer in a case, but without the keyboard. Thus the sequencer could control the Expander Module while the musician played his own keyboard synthesizer.

Oberheim's full-fledged entry into the synthesizer business came in 1975 with the simultaneous introduction of the 2-voice and the 4-voice synthesizers. Both utilized 2 and 4 synthesizer expander modules respectively, with digitally scanning keyboards.

One glaringly apparent problem led to the now patented Oberheim Programmer--namely that with 20 controls on each expander module, the musician had to turn up to 80 knobs to patch a sound. When added to the 2 voice or 4 voice, the programmer allows storage in digital memory and instant recall the setting of the various switches and potentiometers that define a sound.

The oncoming of the low-cost microprocessor has led to a completely programmable polyphonic synthesizer called the OBX, and the upgraded version, the OBXA, as well as the smaller version, the OBSX.

One of the essential elements that made the programmer possible--at least in terms of fitting it into the space available in the 4-voice--was the first voltage controlled envelope generator chip developed by Doug Curtis. The OBX uses the 3310 Voltage controlled envelope generator chip. The OBXA will use the entire Curtis Chip Line, and the OBSX uses the VCA, VCO and the envelope generator chip.

Q. What are your thoughts on digital synthesizers?

A. Well, they have a great future, but I'm not sure the future's here yet. We are going to soon be at a crossroads because digital machines are starting to reach a fair degree of maturity.

But this doesn't mean an end to analog machines because the cost difference is still quite great.

I think what we'll see for a time is the existence of both kinds of machines, and the analog machines will continue to drop in price with equivalent capability of machines now, by more fully exploiting the analog realm.

And eventually digital machines will start to take hold of this market.

Q. What technological milestones have there been that really affected your product design

philosophy?

A. Until the OBX, nothing really significant happened. Although the very first Curtis envelope generator chip allowed us to squeeze everything into the space we had allotted the programmer in the 4-voice, up to that point we pretty much used our own traditional design.

But the mating of microprocessor with analog circuitry allowed the market to really expand.

Q. What do the CES chips mean to the musician?

A. Only things that may not be at all apparent or directly influential on what the musician gets.

The very important intermediate element is the engineer who designs with them. We're using Curtis chips because they allow things to be smaller and less expensive to build.

We're now seeing one of our circuits that hopefully the CES chips will mean an improvement in the quality of the circuit.

The musician is interested in the musical instrument and there's more than one way to implement an instrument. Although he may not realize it, the CES chips end up giving him a more reliable and a more stable machine.

Q. We know you as being very current with the music world. Is "composition" up to date with technology?

A. Let's broaden the term composition to mean the effective use of synthesizers on several levels--composition, performance, whatever--no! Definitely not! The technology has moved so much faster. One example is the OBX--units that come back to Oberheim for repair or modification of one kind or another--probably 4 out of 5 come back to us with our standard factory patch. A lot of people aren't taking full advantage of the machine in combination with their own talents. Another point is as I said, digital machines are starting to make some inroads. But one problem is that they have such incredible capabilities. Very few musicians understand them enough to really make use out of them. That's gonna be the problem. And that's why I think that analog machines will live on for longer than people may think. People are familiar with the analog concept of subtractive synthesis, and the digital additive synthesis technique will take a long time for musicians to learn.

Q. What are you personally most excited about in your company's product line?

A. The expanding synthesizer system which is defined as an OBX type instrument . . . both the OBSX and the OBXA have computer interface

connectors . . . in combination with a computer device being used with a polyphonic sequencer and that in combination with other instruments. I think we're coming on the time when the single composer/musician/performer will have the ability to be totally on his own in terms of producing the whole orchestra sound. Whether its an orchestra, a rock n' roll band, I'm talking about the ability to combine different instruments into a complete integrated system by computer control. That's the most interesting to me.

The other thing that's exciting is the continual evolution of products with components such as CES chips to make our units more cost efficient and continually give the musician more for his money. It's a matter of survival. You can't build a machine that isn't cost effective and expect to do well in the market.

I think we're doing a good job, and we'll continue to work in areas that bring the price of these units down.

**Subscription
Information
on page 15**

THEORY & PRACTICE

The CEM 3340 VCO

Although the CEM 3340 contains virtually everything on-chip, it does allow for enormous flexibility through the proper selection of the few external components. In this issue, we will explore the operation of the 3340 in detail and discuss how to tailor these components for any particular application.

The CEM 3340 consists of basically three sections: the temperature compensation circuitry, the exponential voltage to current converter, and the current controlled waveform generator. A block diagram of the chip along with typical external components is shown in Figure 1.

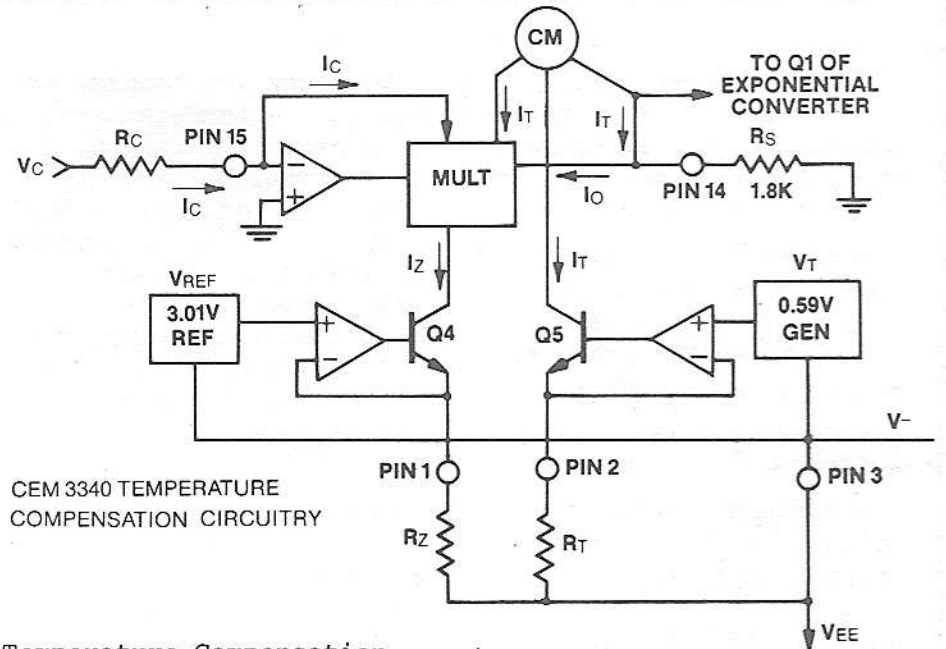

CEM 3340 TEMPERATURE COMPENSATION CIRCUITRY

Temperature Compensation Circuitry

The temperature compensation is made up of a precision current multiplier, a reference current generator, and a temperature dependent current generator. These elements are shown in Figure 2.

A control voltage applied to resistor R_C generates the input current, I_C , into the multiplier, since pin 15 is a virtual ground summing node. This causes a current I_O to flow out of the multiplier which is equal to the input current times the factor I_T/I_Z , or:

$$I_O = -I_C \times \frac{I_T}{I_Z}$$

temperature dependent current I_T
 mult. input current I_C
 mult. reference current I_Z

The current I_T is the input to the multiplier which varies with temperature, and is generated by a 590mV voltage source with a temperature coefficient of +3300ppm. This voltage source is impressed across the resistor R_T and this causes the current I_T to flow through R_T , Q_5 ,

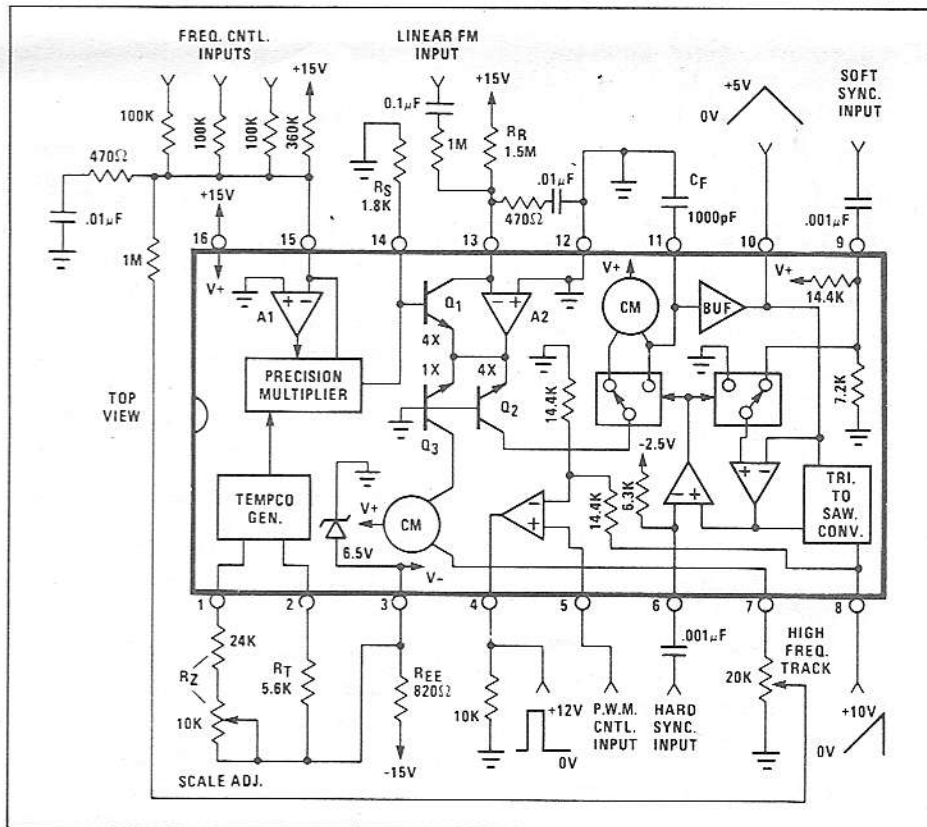

CEM 3340 VCO BLOCK DIAGRAM

and into the current mirror where it is inverted and sent to pin 14 as well as to the multiplier. The reference current I_Z is generated in a similar manner by a very stable (50ppm) voltage source being impressed across R_Z . Thus, unlike I_T which has a temperature coefficient of +3300ppm, I_Z is very temperature stable and may be regarded as a constant. Going back to the first equation, we see that the gain of the multiplier is given by the ratio of I_T to I_Z ; since I_T has a +3300ppm tempco and I_Z has less than 50ppm tempco, the overall gain of the multiplier has very close to a positive 3300ppm temperature coefficient.

Since both I_O and I_T appear at pin 14, the final output current of the multiplier flowing from pin 14 is really the difference between the two, or $I_T - I_O$. This final output current flows through R_S , which converts it into a voltage V_B according to: $V_B = R_S (I_T - I_O)$. From the above discussion we know that I_O has a tempco of +3300ppm because the gain of the multiplier does; we also know that I_T has a tempco of +3300ppm. Thus, the voltage V_B generated across R_S and applied to the input of the exponential voltage to current converter has the positive 3300ppm temperature coefficient which is needed to compensate the exponential converter.

Now that the theory behind the temperature compensation circuitry is understood, we will discuss the specifics of the component value selections. As stated in the CEM 3340 data sheet, for best multiplier linearity, the multiplier gain should be set near unity at room temperature. This means that the current I_T flowing out of pin 2 should be selected to be equal to the reference current I_Z flowing out of pin 1. From the above discussion, we know that $I_T = .59V/R_T$ and $I_Z = 3.05V/R_Z$.

Thus, $\frac{.59V}{R_T}$ should equal $\frac{3.05V}{R_Z}$. No matter what values for R_T and R_Z are selected, they should always meet this equality, or close to it.

The second major consideration in the selection of I_T (and I_Z because they are equal) concerns the most positive voltage on pin 14 which can be obtained, which in turn produces the lowest frequency of the oscillator. Note from figure 2 that as the control current I_C is decreased to zero, the current I_O will also drop to zero. (Because this multiplier operates only in one quadrant, making the current I_C negative will have no further affect on I_O .) Thus at this point, the only

current flowing through R_S will be I_T , producing the maximum positive voltage on pin 14: $I_T \times R_S$.

Suppose you want to be able to drive the oscillator down to 1Hz and it has been determined (from the next section) that this will require a voltage of +180mV on pin 14. From the data sheet, it is stated that for best multiplier accuracy, R_S should always be 1.8K (or as close to it as possible). From the above, the current I_T must therefore be 100μA to generate the +180mV across the 1.8K resistor. Now plugging this back into the equations for R_T and R_Z , we have:

$$I_T = \frac{.59V}{R_T} = 100\mu A \quad \text{and}$$

$$I_Z = \frac{3.05V}{R_Z} = 100\mu A, \quad \text{or}$$

$R_T = 5.9K$ and $R_Z = 30.5K$, and we're done (almost).

Alternatively, suppose you only need to drive the oscillator down to 10Hz. Thus the maximum positive voltage on pin 14 only needs to be +120mV. This means that I_T and I_Z need only be 67μA, and R_T and R_Z are selected to be 8.9K and 45.8K respectively.

In practice, the multiplier gain will have to be trimmed to accommodate resistors tolerances, multiplier offsets, etc. in achieving the desired control scale factor. The resistor to tweak is R_Z ,

so as not to affect the maximum positive voltage on pin 14. Note that with 100K input resistors and a multiplier gain of unity, every 1 volt change in V_C will produce a change of $10\mu\text{A}$ at the input and a corresponding change at the output of $10\mu\text{A} \times 1.8K = 18\text{mV}$, or roughly one octave in frequency. Since the multiplier gain should be kept around unity, the 100K input resistor may be changed to achieve other scale factors. For instance, 30K can be used to generate a scale of 1 decade per volt.

As a final note to this section, if you take all the equations we have discussed so far and put them together, using $22V_T$ for the 590mV voltage source (V_T equals the famous $KT/q = 26.8\text{mV}$ at chip operating temperature), you will arrive at the first equation in the data sheet,

$$I_{OM} = \frac{22V_T}{R_T} \left(1 - \frac{I_C R_Z}{3.0} \right)$$

which I suspect has discouraged many a 3340 data sheet reader from reading on. Our apologies.

The Exponential Converter

The exponential voltage to current converter is the standard type used in virtually all exponential VCO designs. Since numerous detailed explanations of this current exist in the literature, we will not go through its operation other than giving

the appropriate design equation:

$$I_{EG} = I_{REF} \times e^{-V_B/V_T}$$

In this equation, I_{EG} is the current generated in Q2, (output of the converter), which ends up charging and discharging the timing capacitor; I_{REF} is the reference current sourced into pin 13 through R_R ; V_B is voltage at pin 14 which is internally applied to the base of Q1 (input to the converter), and V_T is the famous KT/q which in the past has been the major villain responsible for oscillation drift.

The only other needed bit of information is the current range of this particular exponential converter design: Typically the converter can generate an output current (I_{EG}) from a high of $500\mu\text{A}$ to down to less than 1nA , or a 500,000:1 range. This current together with value of the timing capacitor, C_F , is what determines the final frequency of the oscillator, as given in this important equation (this is the last one, I promise):

$$f = \frac{I_{EG}}{2C_F \times 1/3 V_{CC}}$$

(V_{CC} is positive supply voltage applied to pin 16, Typically +15V.)

Therefore, knowing what currents the exponential generator is capable of delivering, we can then select the capacitor C_F to

give the desired range of frequencies. But before we do this, we should be aware that the converter has the greatest accuracy between 50nA and $100\mu\text{A}$ (a 2,000:1 range).

Suppose that we want the VCO to cover the normal audio range with the greatest accuracy, from 5Hz to 10KHz. The 5Hz should occur when the current is 50nA and the 10KHz should occur when the current is $100\mu\text{A}$. Using the above equation, we calculate $C_F = 1000\text{pF}$ to give us these numbers. Note that with this value of capacitor, the oscillator can be swept from 0.1Hz to 50KHz maximum.

Suppose instead we want the oscillator to have the greatest accuracy from 50Hz to 100KHz, with a maximum sweepable range of 500KHz (about the upper limit) down to 1Hz. The timing capacitor then becomes 100pF . Or suppose we want an LFO with an accurate range from .005Hz to 10Hz and a maximum sweepable range from .001Hz (almost 3 hours) to 50Hz. The timing capacitor then calculates out to $1\mu\text{F}$.

Finally, we need to select the value of the reference current sourced into pin 13. This current is not critical as long as it is stable. For best results, it should be selected in the 3 to $15\mu\text{A}$ range. This puts it near the geometric middle of the accurate current range of the converter but still high enough so as not to be affected significantly by the input bias current

of op amp A2. The actual value selected, however, does determine the range needed for V_B to produce the desired frequency range; and the range needed for V_B in turn determines the values required for R_T and R_Z as explained in the previous section. I have underlined this sentence because after C_F is selected, it is the meat of the matter for component selection.

The following example should illustrate: Suppose we have selected the timing capacitor at 1000pF to give an accurate frequency range of 5Hz to 10KHz, but we want the frequency to be sweepable from 1Hz to 20KHz. For 1Hz, the previous equation tells us that the converter current, I_{EG} , will be 10nA. Now suppose we select the reference current to be 10 μ A. From the first equation of this section, we then calculate V_B must be approximately +180mV at room temperature ($V_T = 26mV$ at 25°C) to generate a current of 10nA from a reference current of 10 μ A. This +180mV is the maximum positive voltage required at pin 14, and from the previous section, is the number we use to calculate the components associated with the temperature compensation circuitry.

Note that to generate 20KHz, the converter current must be 200 μ A, which results with a pin

14 voltage of -78mV. The multiplier has no problem producing this voltage and can easily sweep the frequency up to its maximum of 50KHz.

As a final note, all the components we have been discussing should be of the highest quality for best oscillation stability. The timing capacitor should be mica or a low TC film (polystyrene has a tempco usually around -200ppm); R_Z , R_T , R_S , R_R , and all input resistors to pin 15 should be 1% metal film with $\pm 50ppm$ or less tempco, and the scale adjust trimmer should be cermet or other high stability type.

The Current Controlled Oscillator

The oscillator itself is a triangle waveform based type. The output current of the exponential converter goes through a switch which connects it to the timing capacitor either directly for discharging or through an inverting current mirror for charging. The capacitor is isolated with a low input current buffer which applies the triangle output to the switching comparator input. Another switch connects either ground or a resistor divider tap to the other comparator input to determine the switching thresholds. Hence, the lower level on the triangle output is zero volts, while the upper level is one-third of the positive supply voltage.

The triangle waveform is

converted to a sawtooth with a circuit which inverts the triangle right after the upper switch point is reached. Because of the precision of this circuit, no waveform trimming is necessary. Finally, the sawtooth output is applied to a standard comparator, where it is converted into a variable width pulse waveform.

Because most exponential VCO designs seem to be based on generating a sawtooth waveform first, many people asked why the CEM 3340 is triangular based. The reasons are many and have to do with achieving better accuracy and better stability. The most important are listed below for the record:

- 1) The buffer input bias current affects the frequency by only one over the square: A bias of 1nA causes 1% error for a 100nA charge current in a sawtooth VCO, but only .01% for a triangle VCO.
- 2) Buffer offset voltage does not have to be well defined or temperature stable. In a sawtooth VCO, however, these parameters can cause drift.
- 3) In a sawtooth VCO, reset time causes error. This is not a problem for a triangle VCO.
- 4) A triangle VCO can be designed with no saturating transistors, resulting in less comparator switching delay and scale error. A sawtooth VCO designed without saturating transistors is likely to

have large waveform overshoot due to propagation delays; this overshoot causes even more error.

Summary

We hope the foregoing discussion has clarified how the CEM 3340 works and how the external components should be selected. As a quick review, we list the proper sequence for component selection below:

- 1) Select C_F for the desired frequency range with greatest accuracy.
- 2) Select a convenient value of the pin 13 reference current.
- 3) Determine the range for the pin 14 voltage (V_B) required to give the desired sweepable range.
- 4) Calculate R_Z and R_T based on the most positive value of V_B as determined above.
- 5) Select the input resistors to pin 15 for the desired control scale (R_S should always be 1.8K).

Next issue we will reveal the inner working of the CEM 3310 Envelope Generator.

¹Bernie Hutchins, Musical Engineer's Handbook, Chapter 5b, pages 8-14
Daniel H. Sheingold, Nonlinear Circuits Handbook, Chapter 1, Part 3, pp 165-201.

HOT TIPS & CHIP BITS

In this column, we will present helpful application hints that we or our customers have discovered while applying our ICs in actual circuits. With chips as complicated and flexible as these, there's bound to be some application tricks that didn't make it into our data sheets. So please tell us about those nuances, circuit subtleties, and clever tricks you have uncovered, and we will pass the information on to our readers.

The first chip-bit we spotted has to do with the CEM 3330 Dual VCA. It turns out that when the linear control input is reduced so that the gain is -80db or less, the log converter breaks in oscillation. It's not surprising it took us so long to learn about it (actually, some of our customers discovered it). First of all, it's very hard to adjust the linear input for -80db, because this represents only several millivolts above the input offset or .01% of full scale. And when you can get the circuit to oscillate, very little of the oscillation, if anything, comes out at the output because the gain is -80db. However, under some conditions, it apparently can couple into other parts of the circuit and be heard.

Fortunately, the fix is quite simple and, we're embarrassed to say, it also results in less

external components. Instead of compensating each log converter with a series .01 μF capacitor and 1K resistor from the linear control input to ground, as shown in the data sheet, a .001 μF or larger from each linear control input to the corresponding reference current input will keep the log converters stable at all gain settings. The new and old compensation is shown in the accompanying figure. We apologize for this goof and any inconvenience it has caused you.

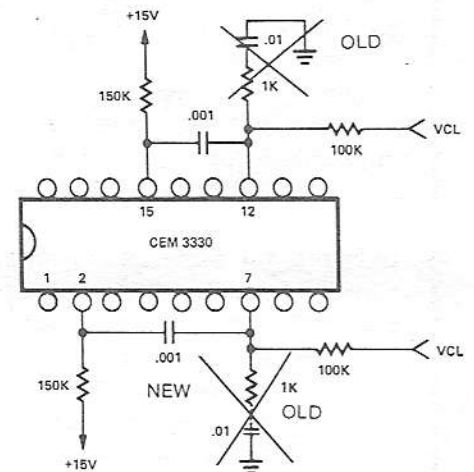

IMPROVED COMPENSATION FOR THE CEM 3330 DUAL VCA

Another ^{NEW} of those subtleties we discovered has to do with the CEM3340 VCO. Apparently, if you have two oscillators adjacent to each other on the same PC board tracking each other very close to unison (within 1/4 beat per second) they can lock up to each other. This, of course, destroys one of the big advantages to analog oscillators--the ability for random and

continued on page 15

APPLICATIONS CORNER

In this first issue, we will examine some unique ways of applying the CEM 3310 Envelope Generator to achieve envelope functions not normally found in today's synthesizers. The envelope generator has been given little attention over the years; yet the shape and duration of a tone's various envelopes--amplitude, frequency, and harmonic--give a sound its distinctive sonic characteristic, probably more than any other parameter.

Application #1 - Selectable Triggering Modes

The circuit shown in Figure 1 was designed to provide more triggering possibilities than normally available with just the gate, or the gate and trigger on some monophonic synthesizers. One characteristic of conventional triggering is that one must hold the key down until the envelope has reached its peak in order to realize a full envelope. This new circuit, however, allows one to briefly strike a key to initiate the envelope; the envelope will automatically rise to its peak, decay to the sustain level, and then release back to zero. This feature is especially useful for long attacks where one can initiate the envelope and then go on to other things while the envelope is slowly progressing through its phases. We will call this mode "automatic" or "auto."

Another shortcoming of

conventional triggering is that it is difficult to simulate piano type envelopes, which have short attacks, decays which are very brief at the beginning and then long thereafter, and a short release corresponding to the damper rejoining the string. By using the auto mode and adding a circuit which sets the release time to its shortest value whenever the gate signal goes low, this type of piano envelope can be more closely simulated. We will call this mode "damped."

Figure 1 shows the complete circuit of a voltage

controlled envelope generator with switch selectable Normal gate mode, Auto mode, and Damped mode.

Besides the CEM 3310, the circuits consist of a dual op amp--one acting as a comparator to detect when the sustain level has been reached (A2) and the other acting as a set-reset flip-flop (A1)--and a pair of transistors (Q1 and Q2) for shorting the release control voltage to 0 in the damped mode.

With the Normal mode selected, the gate output from the keyboard is inverted to the non-invert-

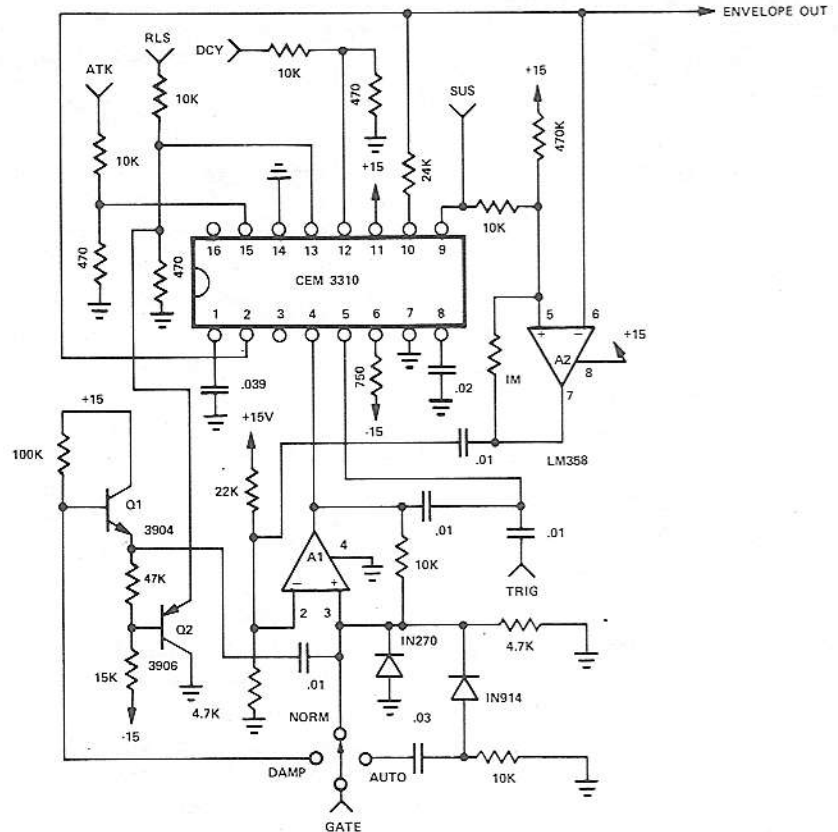

FIGURE 1: SELECTABLE TRIGGERING MODES

ing input of A1. A high level signal (>2.8V) will switch A1 output high and provide a trigger pulse to pin 5 of the 3310. If a trigger pulse is also available from the keyboard, it may be applied to the trigger input for retriggering of the envelope while the gate is still high.

In the Auto mode, the positive going transition of the keyboard gate will flip A1's output high, providing the traditional gate and trigger pulse to the 3310. After the envelope has progressed through the attack phase and when it has decayed to within 100mV of the sustain level (as determined by the positive feedback resistor and pull-up resistor connected to the non-inverting input of A2), the output of A2 will switch high, providing a positive pulse to A1; this pulse will cause A1 to switch its output back low and allow the envelope to release to zero. Note that the point at which the gate returns low has no consequence.

For the Damped mode, the keyboard gate is applied to the base of Q1 and the keyboard trigger (if any) applied to the trigger input for retriggering. Whenever the gate signal goes high, it will couple a positive pulse to A1, flipping it high and causing the envelope to automatically progress as in the Auto mode. However, when the gate goes low again, it will flip A1 back low (if it has not already been set low by A2), ensuring that the

envelope is in the release phase. At the same time, Q2 (which is being operated in the inverse mode for low offset) turns on and shorts the release control voltage to 0 volts, thus causing the envelope to release to zero in several milliseconds.

All three modes are musically very useful, and hopefully will begin appearing in future synthesizers.

Application #2 - Envelope Amplitude Control

Pin 3 of the CEM 3310 connects to an internal resistor divider which sets the peak threshold voltage of the envelope. This tap was originally brought out to allow the maximum sustain level to be matched to the peak level as described in the 3310 data sheet. However, another very useful application of this pin is to allow the envelope peak to be voltage controllable. If such an envelope were controlling a VCA, for instance, this additional control input would allow the overall tone volume to be controlled without the use of another VCA. Thus, a pressure sensitive or velocity sensitive keyboard could easily impart dynamics to the notes being played by using this feature.

Figure 2 shows how pin3 may be used to control the envelope amplitude. The low impedance output of the op amp drives the peak threshold input and overrides the voltage set up by the internal resistor divider. In this case the

op amp is part of a Sample and Hold, so that a micro-processor can determine the pressure or velocity with which a key is struck, and load the Sample and Hold with the appropriate voltage. Note that to keep the same relationship between the envelope peak and the sustain level, the sustain level voltage is derived from the op amp output. If the sustain voltage were to come from the computer as well, the computer would be required to adjust the sustain

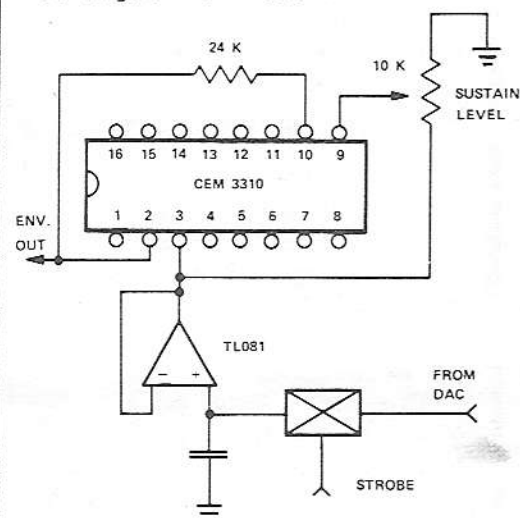

FIGURE 2: ENVELOPE AMPLITUDE CONTROL

voltage in accordance to the value at which it set the peak.

When driving pin 3 with an external voltage, care should be exercised to prevent this voltage from being greater than 5.5 volts.

Application #3 - Selectable Envelope Shape

The vast majority of envelope generators produce the rising and falling curves of the envelope with the same shape, and the CEM 3310 is no exception: The attack portion

of the envelope rises logarithmically while the decay and release portions fall exponentially. Although natural instruments almost always produce the exponential curve for their decays, the attacks often have shapes other than logarithmic. It was therefore the intent of this application to allow different curves to be selected for the attack. Of course, as long as we were at it, we decided to make the decay and release portions have independently selectable curve shapes as well.

The complete circuit is shown in Figure 3. Each envelope portion has two switches to allow one of four different curves to be selected; logarithmic, linear, exponential, or S-shaped.

Operation of the circuit is as follows:

The three CMOS gates, G1, G2, and G3 produce high levels during the attack, decay, and release portions of the envelope respectively, turning on each of the CMOS switches in turn. If a "norm-lin" switch is in the normal position, and the corresponding "reverse" switch is open, the envelope output will be connected to the feedback input (pin 10) during that portion of the envelope, resulting in the normal envelope shape (logarithmic for attack, exponential for decay and release).

If however, the "norm-lin" switch is in the linear position, a fixed voltage will be connected to the feedback input, and

the resulting curve shape will be linear during that portion of the envelope. The purpose of the 43K resistor and parallel diode is to allow the attack time to be roughly the same as the decay and release times.

Whenever a "reverse" switch is closed it connects the envelope output to the corresponding control input. In the case of the attack, the attack will become faster as the envelope rises; while for the decay and release, since the feedback is inverted by A1, the output will fall faster as it approaches zero. Thus, with the corresponding "norm-lin" switch in the linear position, the envelope shape will be opposite to that which it normally is (exponential for attack,

logarithmic for decay and release).

Finally with the reverse switch closed and the "norm-lin" switch in the normal position, a S-curve will result, being most noticeable for the decay and release portions of the envelope.

The purpose of A2 is to prevent the output from going below the sustain level during the decay phase, and below zero during the release phase whenever the output is not being connected to the feedback input (pin 10).

With some 64 different combinations possible, this circuit should provide good variety in your envelopes. The different curves for the attack are probably the most musically useful, but the others can be had with little extra hardware.

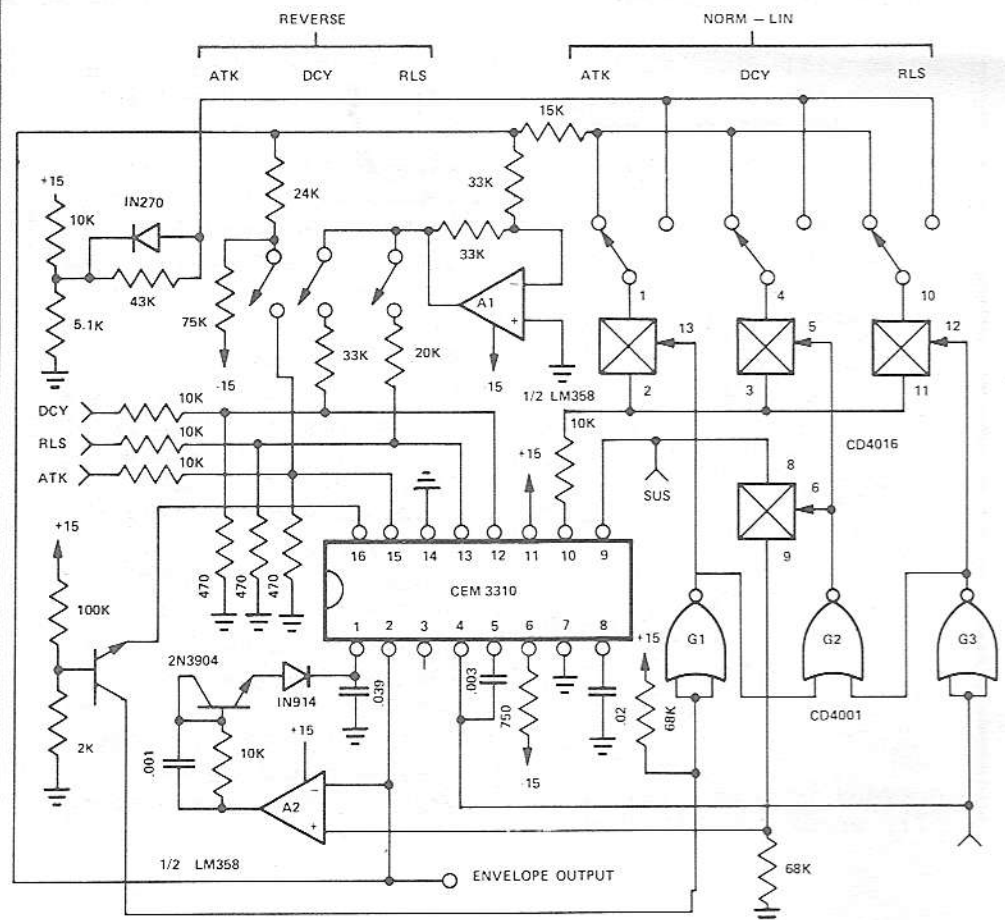

FIGURE 3. SELECTABLE ENVELOPE SHAPE

ever changing phase relationships. The reason, we discovered, is that the reference current input (pin 13) is very sensitive to stray pick-up, being high impedance and low current. Thus, any nearby fast transistion signals, such as the pulse output from the neighboring VCO, will couple enough energy into the exponential converter to synchronize the triangle waveform.

Avoiding this problem entirely requires only careful P.C. board layout. The trace to pin 13 should be kept short, the associated components connected to this pin, especially the compensation network, should be situated close by the IC, and signal carrying traces should be located away from these components.

Hope these hot tips have helped you out.

Concept and Design by
PACIFICO & ASSOCIATES, INC.

SUBSCRIPTION INFORMATION

Synthesource came into existence because of the many calls and letters we received from our very creative and ingenious customers around the United States and the world. As we listen to your questions, ideas and plans for future products, we felt that there needed to be a forum where electronics for the musical imagination could be pursued to their fullest.

But, the costs of simply printing and mailing are high and ever-rising, so we must charge an annual subscription fee of \$12.50. This sum will cover our material costs, we hope. But more importantly, this subscription will guarantee you a quarterly update on the products, technolo-

gies, personalities and innovations that shape the state-of-the-art. We are dedicated to being a resource for the musical instrument designer: hence our name Synthesource.

COMING NEXT ISSUE:

Interview with Dave Smith of Sequential Circuits

The Inside Workings of V.C. Envelope Generators

Filter Applications: New Sounds from Unusual Filter Responses

And the very first Reader's Design Corner (in which circuits developed by you will be featured - so send us your circuit)!

And more HOT TIPS and CHIP BITS!

© 1981 Curtis Electromusic Specialties, Inc. No portion of this may be reproduced without experss written permission from Curtis Electromusic Specialties (CES). CES assumes no responsibility for use of any circuitry described. No circuit licenses are implied. CES reserves the right, at any time without notice, to change said circuitry. Printed in U.S.A.

CLIP THIS COUPON AND ATTACH YOUR CHECK FOR \$12.50
(No Cash Please!)

Name _____

Company _____

Address _____

City _____ State _____ Zip _____

Phone _____

Products being Developed/Manufactured: _____

I'd like to write an article on: _____

I'd like to know more about: _____

Please send product information on: CEM 3310, 3320, 3330/35, 3340/45, 3350, 3360, and CEV 3301

Free Premier Issue

FIRST CLASS MAIL

Paul Dronogowski
644 So. 8th E. #12
Salt Lake City
Utah 84102



URTI'S ELECTROMUSIC SPECIALTIES INC.
110 Highland Ave. Los Gatos, CA. 95030
(408) 395-3350 • TWX-910-338-2025



PREMIER ISSUE!
Introducing the quarterly newsletter of
musical instrument design
SYNTHESOURCE

In This Issue:

Tom Oberheim speaks out on giving the musician more for his money P. 1

CES New Products Preview:
The 3350 Dual State Variable Voltage Controlled Filter, the 3360 Dual VCA and the CEV 3301 Evaluation Board P. 1

Theory & Practice: An Inside Scoop on the 3340 VCO P. 7

Applications Corner: Unusual Envelope Functions from the 3310 P. 12

PLUS Hot Tips and Chip Bits! P. 11